

SERIES F

WITH ESCO MULTICROWN TOOTH FORM FOR LONG LIFE

Maximum torque: up to 5 040 000 Nm „ Bore: up to 1 130 mm

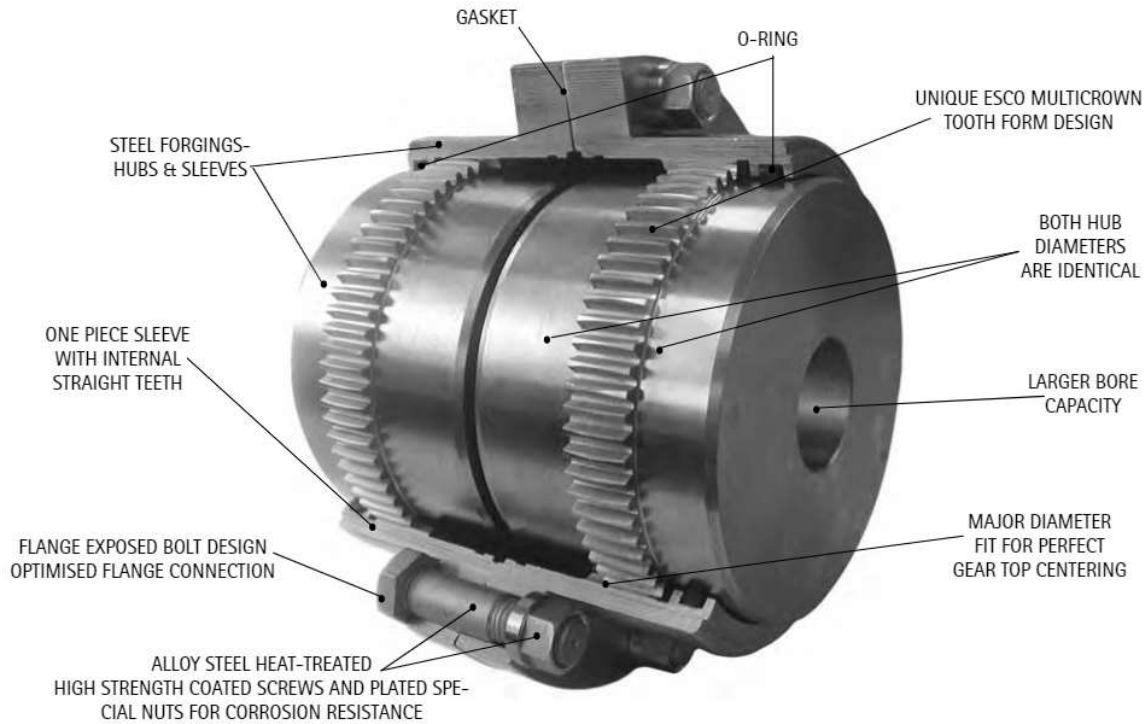

LOWER STRESSES

The ESCO MULTICROWN tooth form is a curve with constantly changing radii of curvature. The tooth contact area under misaligned conditions has a much larger radius of curvature than conventional crowning. The contact area therefore is larger thus reducing the surface stresses.

CONSTANT VELOCITY POWER TRANSMISSION

ESCO generates the ESCO MULTICROWN, tooth in such a way that the necessary characteristics for homocinetic conjugate tooth action are perfectly achieved.







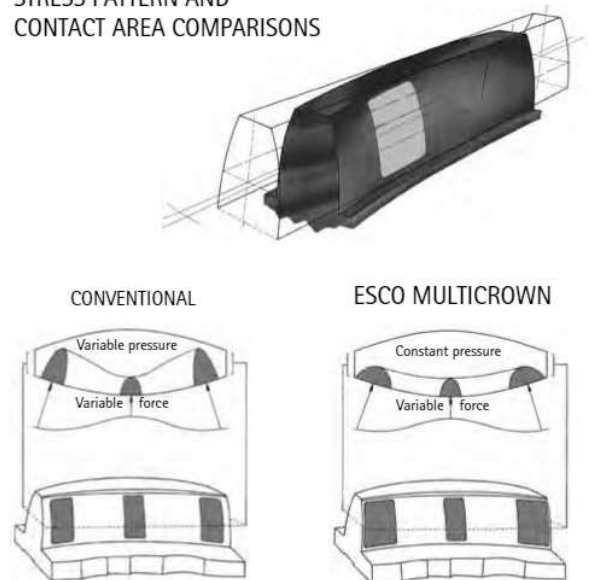



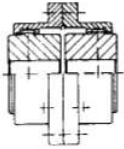

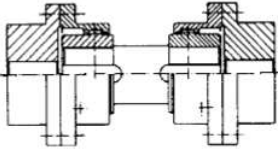
LESS BACKLASH

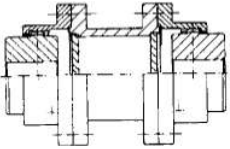

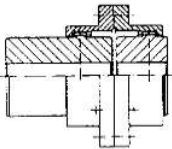

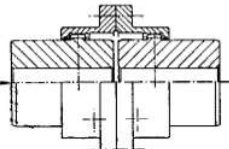

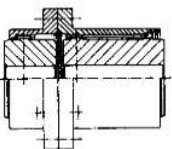

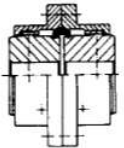

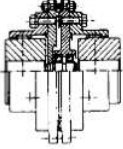
The ESCO MULTICROWN tooth design requires less backlash for a given angle of misalignment than the conventional crowning, thus reducing shocks in reversing application.

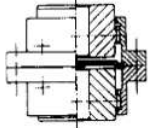
STRESS PATTERN AND CONTACT AREA COMPARISONS

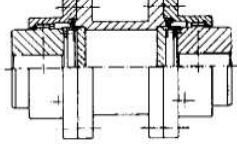

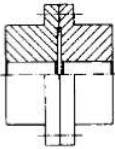
AVAILABILITIES

FST	 ← B410 & B411	
STANDARD		
FFS	 ← B412	
FLOATING SHAFT		
FSE	 ← B413	
SPACER EXECUTION		
FMM	 ← B414	
MILL-MOTOR		
FDMM	 ← B415	
DOUBLE MILL-MOTOR		
FSH	 ← B416	
SLIDING HUB		
FLE	 ← B417	
LIMITED EN FLOAT		

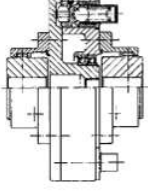
		Bolts and nuts (metric)	Bolts and nuts (conform to AGMA 516.01)
		Exposed metric "EM"	Exposed inch "EI"
FSP	 ← B418		
SHEAR PIN			
FSV	 ← B419		
STANDARD VERTICAL			
FSLE	 ← B420		
LIMITED END FLOAT			
FRR	 ← B421		
RIGID - RIGID			
FWD	 ← B422		
WINCH DRUM			
FET	 ← B423		
WITH ESCOTORQUE			

OTHER TYPES AVAILABLE (on request)

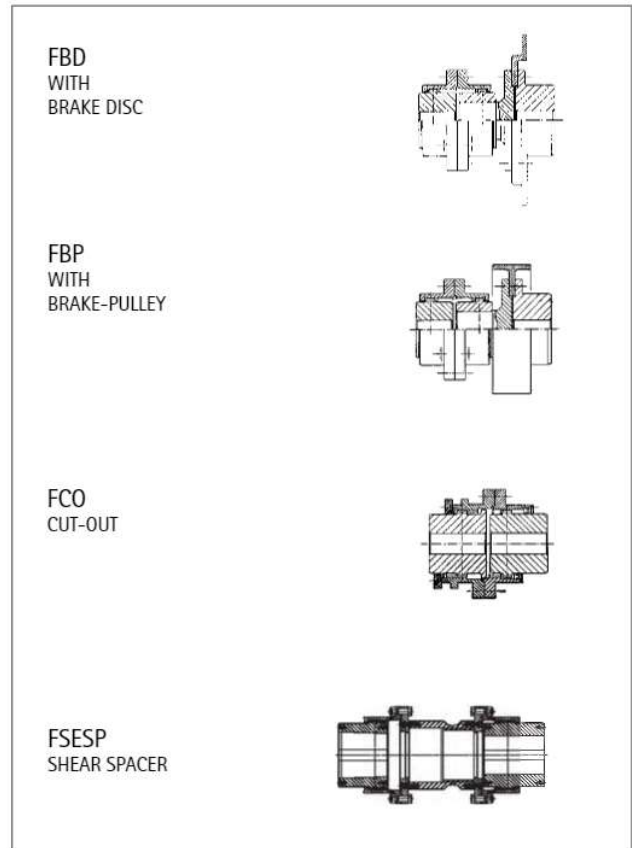
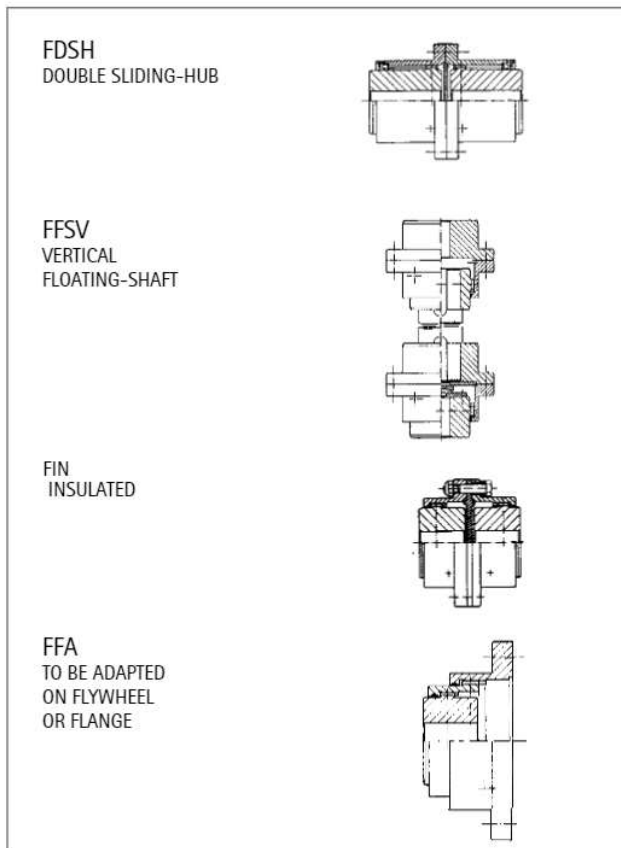

Only a few special types of couplings are illustrated. Additional special types are available on request.

SHAFT CONNECTIONS

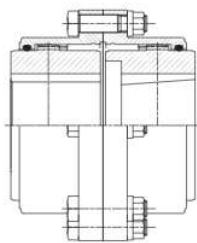

KEYWAY

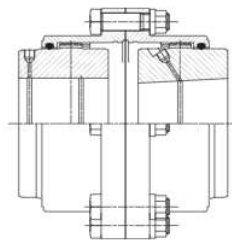

INTERFERENCE FIT

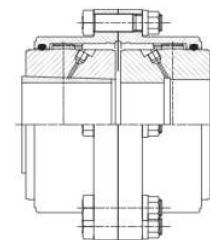

INTERFERENCE WITH
INTERMEDIATE CONICAL BUSHING

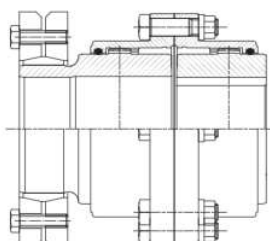

EXTERNAL CLAMPING

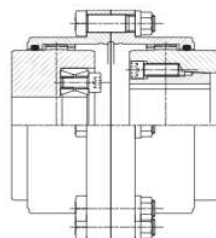

INTERNAL CLAMPING

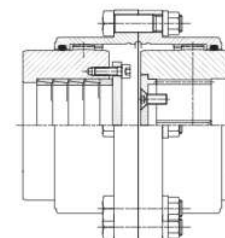

SPLINES

HOW TO SELECT THE RIGHT COUPLING SIZE

A. Select the size of ESCOGEAR coupling that will accommodate the largest shaft diameter.

B. Make sure this coupling has the required torque capacity according to following formula: $\text{torque in Nm} = \frac{9550 \times P \times F_u \times F_{\epsilon_x}}{n}$

P = power in kW; n = speed in rpm; F_u = service factor according to tabulation 1.

$F_{\epsilon_x} = 2$ in case of use in potentially explosive atmospheres ϵ_x , European Directive 94/9/EC. In normal atmospheres, $F_{\epsilon_x} = 1$.

The coupling selected per (A) must have an equal or greater torque capacity than the result of the formula (B). If not select a larger size coupling. Check if application peak torque does not exceed tabulated peak torque T_p indicated planographs B410 to B423.

Check also max. allowable misalignment using the graph of tabulation 2.

C. Check if shaft/hub connection will transmit the torque. If necessary, select a longer hub.

D. Read carefully assembly and maintenance instructions IM/B400.

DRIVEN MACHINE		APPLICATIONS	DRIVER MACHINE		
			Electric motors Turbines	Hydraulic motors Gears drivers	Reciprocating engine Electric motors frequent starts
UNIFORM	Generators - Blowers: centrifugal vane, fans - Centrifugal pumps and compressors - Machine tools: auxiliary drives - Conveyors: belt and chain, uniformly loaded, escalators - Can filling machines and bottling machinery - Agitators: pure liquids.	0,8 to 1,25	1 to 1,5	1,25 to 1,75	
		1,25	1,5	1,75	
	Propeller - Waterjet pumps				
MODERATE SHOCKS	Blowers: lobe - Pumps: gear and lobe types - Vane compressors - Machine tools: main drives - Conveyors: belt and chain not uniformly fed bucket and screw - Elevators, cranes, tackles and winches - Wire winding machines, reels, winders (paper industry) - Agitators liquids and solids, liquids variable density.	1,25 to 1,5	1,5 to 1,75	1,75 to 2	
HEAVY SHOCKS	Generators (welding) - Reciprocating pumps and compressors - Laundry washers - Bending roll, punch press, tapping machines - Barkers, calanders, paper presses - Briquetter machines, cement furnace - Crushers: ore and stone, hammer mill, rubber mill - Metal mills: forming machines, table conveyors - Draw Bench, wire drawing and flattening machines - Road & railroad equipment.	1,5 to 2	1,75 to 2,25	2 to 2,5	

1) MAXIMUM MISALIGNMENT

TABULATION 2

GRAPH (T, n)

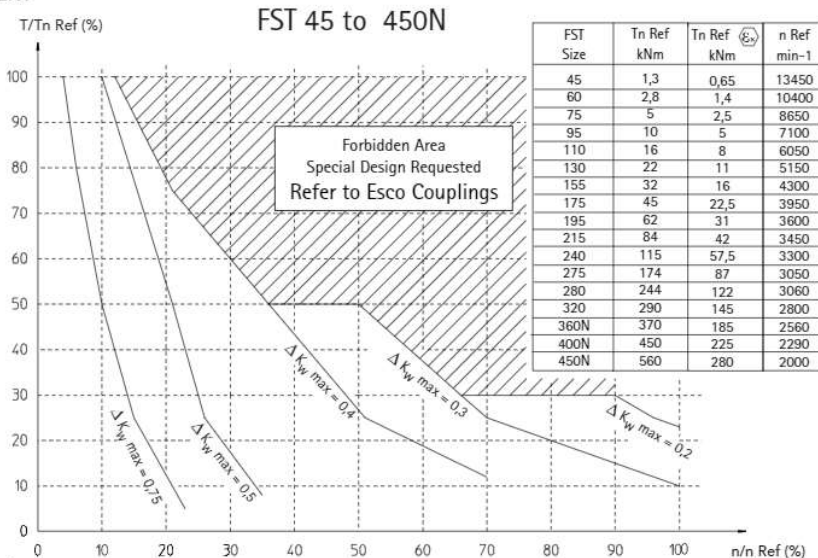

HOW TO USE THE GRAPH (T,n) ?

Maximum torque, maximum speed and maximum misalignment may not occur simultaneously.

Graph must be used as follows:

1. Calculate T_n and T_p and select coupling size as usual. T_n = nominal torque; T_p = peak torque
2. Calculate $T_n/T_n\text{Ref}$ and $n/n\text{Ref}$ and plot the resulting point in the graph.
3. If the resulting point is located in the white area, a standard coupling may be used as far as maximum misalignment doesn't exceed the maximum misalignment indicated in the graph.
4. If the resulting point is located in the shaded area, refer to ESCO COUPLINGS
5. In case of use in potentially explosive atmospheres ϵ_x , proceed the same way but using $T_n\text{Ref}(\epsilon_x)$ for the calculation. Max misalignment may not exceed 0,5° per gear mesh.

2) MINIMUM MISALIGNMENT = $\Delta K_{wmin} = 0,1^\circ$

3) MISALIGNMENT CONTROL

1- Measure X (TIR) - 2- Measure Y-Z - 3- Verify the relationship for the misalignment control: $\Delta K_{wmin} \leq \frac{X}{K_x} + \frac{Y-Z}{K_y} \leq 0,75 \times \Delta K_{wmax}$

$$K_x = K_{x0} + \frac{S}{30} \text{ with } S = \text{Spacer length (mm)}$$

(If no spacer: $S = 0$)

$$K_y = K_{y0}$$

FST	K_{x0}	K_{y0}
45	1,92	2,34
60	2,06	3,04
75	2,76	3,71
95	3,25	4,54
110	3,80	5,28
130	4,47	6,22
155	5,03	7,55
175	5,72	8,20
195	6,35	9,18
215	7,47	9,98
240	8,24	11,04
275	9,18	12,98
280	10,82	13,76
320	11,34	15,08
360	12,32	16,76
400	13,37	18,50
450	14,35	20,74

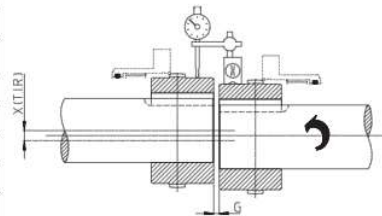
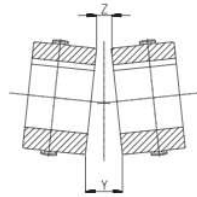

4) EXAMPLES:

Calculation

$$\left. \begin{array}{l} T/T_n \text{ ref} = 30\% \\ n/n \text{ ref} = 30\% \end{array} \right\} \Delta K_{wmax} = 0,4^\circ$$

FST 175: $K_x = 5,72$ $K_y = 8,2$

Measurement

X (TIR) = 0,9 mm Y-Z = 0,4 mm

Control

Formule:

$$\Delta K_{wmin} \leq \frac{X}{K_x} + \frac{Y-Z}{K_y} \leq 0,75 \times \Delta K_{wmax}$$

Calculation : $0,1^\circ \leq \frac{0,9}{5,7} + \frac{0,4}{8,2} \leq 0,75 \times 0,4$ ok

LEGEND OF USED PICTOGRAMS		Notes for series F	
	MAXIMUM NOMINAL BORE (mm)	<ol style="list-style-type: none"> For key according to ISO R 773. Gear maximum continuous transmissible torque for the tabulated misalignment. The effective transmissible torque depends on the bore and shaft/hub connection. Higher speed on special request. For grease withstanding centrifugal acceleration of 1.000g. See installation and maintenance manual IM. For grease withstanding centrifugal acceleration of 2.000g. See installation and maintenance manual IM. Depends on S. For long operation in disconnected position contact us. For solid bore. Depends on S. For solid bore and S minimum. Per 100 mm spacer length. Depends on L and R. For pilot bored hubs. Depends on S. For pilot bored hubs and S minimum. Per 100 mm spacer length. Depends on L and R. See installation and maintenance manual IM. Depends on S. Values given for S maximum. On request. For larger S contact us. Values for S minimum. S maximum depends on torque and speed. G must remain constant during operation. Needed to control the alignment and inspect the gears. 	
	MINIMUM BORE (mm)		
	MAXIMUM BORE (mm)		
	T_n		MAXIMUM NOMINAL TORQUE (Nm)
	T_p		MAXIMUM PEAK TORQUE (Nm)
	MAXIMUM SPEED (rpm)		
	MAXIMUM OFFSET (mm)		
	MAXIMUM ANGULAR MISALIGNMENT (degree)		
	INERTIA (kgm ²)		
	WEIGHT (kg)		
	GREASE QUANTITY (dm ³)		

* Max. torque, speed and misalignment tabulated values may not be cumulated See IM/B400.

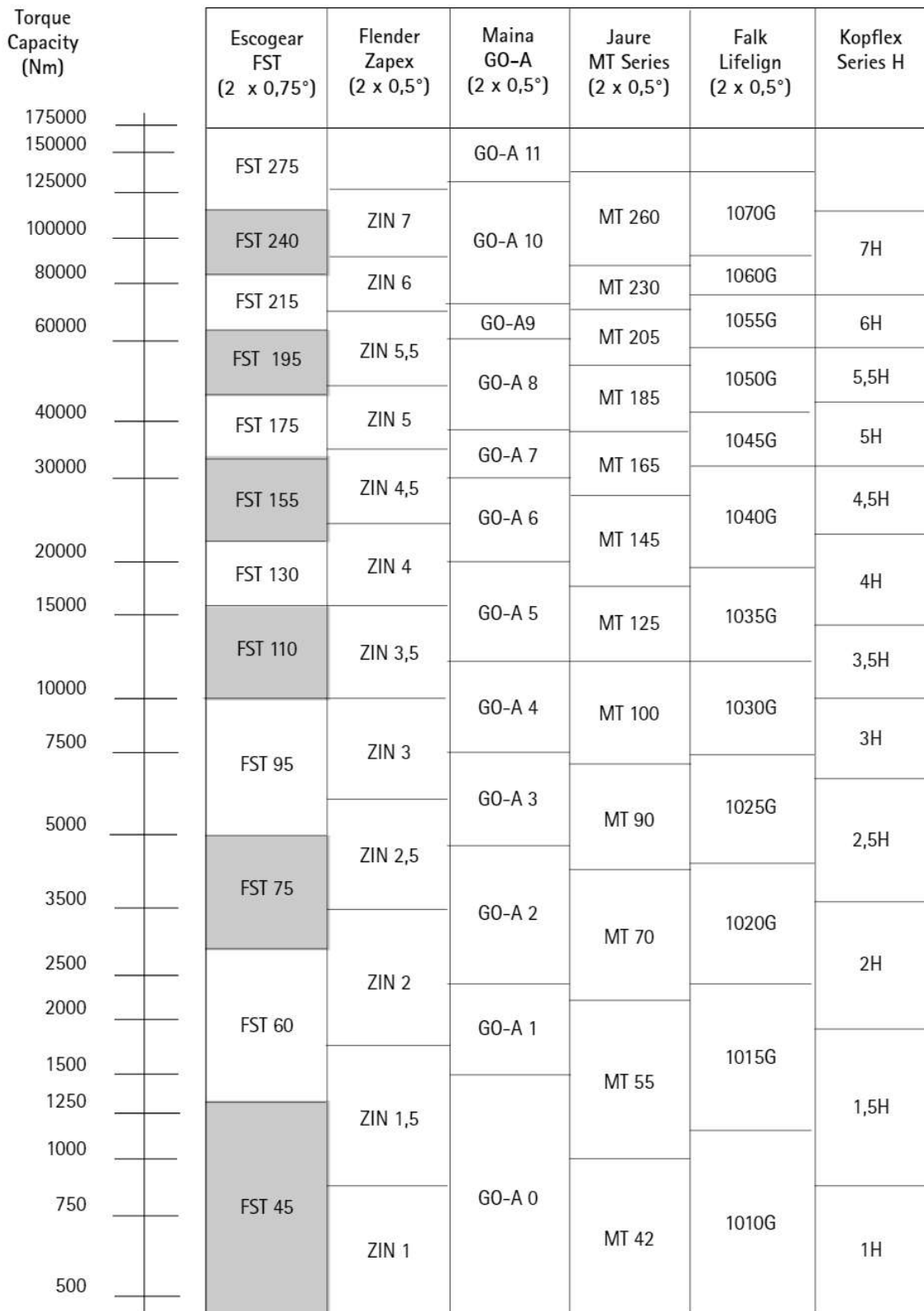

Remark: When selecting based upon the above equivalent chart, please check bore capacity of escogear coupling against the application requirements.

ESCO	LOVEJOY	FALK	KOP-FLEX	AMERIDRIVES	AJAX
FST	F	G20, G10	H	F	6901
45	1	1010	1	101	1
60	1 1/2	1015	1 1/2	101 1/2	1,5
75	2	1020	2	102	2
95	2 1/2	1025	2 1/2	102 1/2	2,5
110	3	1030	3	103	3
130	3 1/2	1035	3 1/2	103 1/2	3,5
155	4	1040	4	104	4
175	4 1/2	1045	4 1/2	104 1/2	4,5
195	5	1050	5	105	5
215	5 1/2	1055	5 1/2	105 1/2	5,5
240	6	1060	6	106	6
275	7	1070	7	107	7



Cement kiln mill drive



Vertical mixer drive

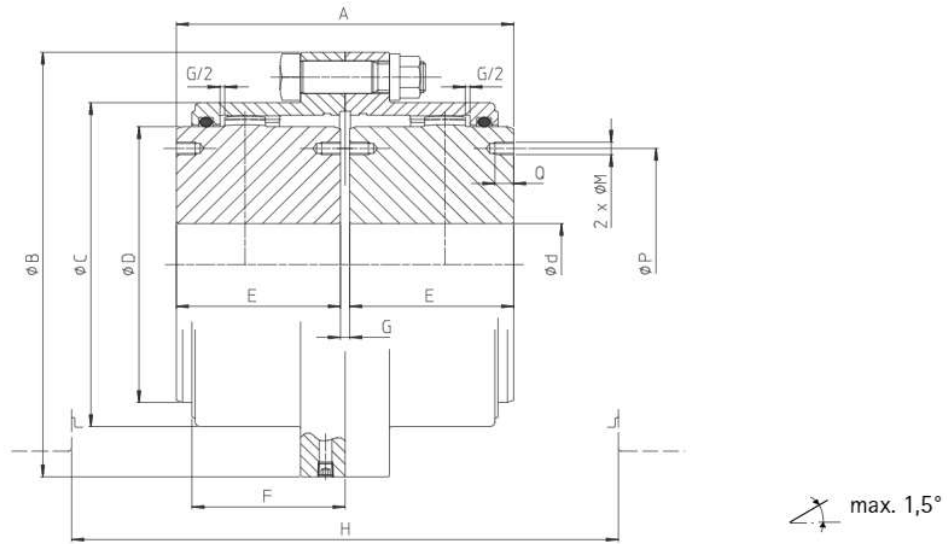

← A150		Type FST													
		45	60	75	95	110	130	155	175	195	215	240	275		
	d Ø nominal max.	mm	45	60	75	95	110	130	155	175	195	215	240	275	
	d Ø min.	mm	0	0	0	0	0	55	65	80	90	100	120	150	
	* d Ø max.	mm	50	64	78	98	112	132	158	175	198	217	244	275	
	Tn	Nm	1300	2800	5000	10000	16000	22000	32000	45000	62000	84000	115000	174000	
	Tp		2600	5600	10000	20000	32000	44000	64000	90000	124000	168000	230000	348000	
	3.1	tr/min	5000	4400	4000	3600	3350	3100	2800	2700	2550	2450	2300	2150	
	3.2	omw/min rpm min ⁻¹	7000	6200	5650	5100	4700	4350	4000	3800	3600	3450	3300	3050	
	—	degré graad degree Grad	2x0,75	2x0,75	2x0,75	2x0,75	2x0,75	2x0,75	2x0,75	2x0,75	2x0,75	2x0,75	2x0,75	2x0,75	
	—	mm: ±	0,35	0,4	0,5	0,6	0,7	0,9	1	1,1	1,2	1,4	1,5	1,7	
	4	kgm ²	0,005	0,015	0,040	0,105	0,191	0,430	0,842	1,320	2,448	3,716	5,384	10,872	
	5	kg	4,1	8,0	14,6	26,1	38,8	59,2	89,4	117,5	167,1	222,4	275,0	413,6	
	6	dm ³	0,05	0,07	0,13	0,21	0,36	0,52	0,80	0,98	1,51	2,02	2,43	3,29	
mm: ±	A	mm	89	103	127	157	185	216	246	278	308	358	388	450	
	B	mm	111	141	171	210	234	274	312	337	380	405	444	506	
	C	mm	80	103,5	129,5	156	181	209	247	273	307	338	368	426	
	D	mm	67	87	106	130	151	178	213	235	263	286	316	372	
	E	mm	43	50	62	76	90	105	120	135	150	175	190	220	
	F	mm	41	47	58,5	68,5	82	98	108,5	121	132	151,5	165	183,5	
	G	mm	3	3	3	5	5	6	6	8	8	8	8	10	
	H	10	mm	147	166	212	249	295	350	392	440	484	562	616	688
	M	mm									M 12	M 16	M 16	M 16	M 20
	P	mm									205	226	250	276	330
Q	mm									18	24	24	24	30	

* Consult us

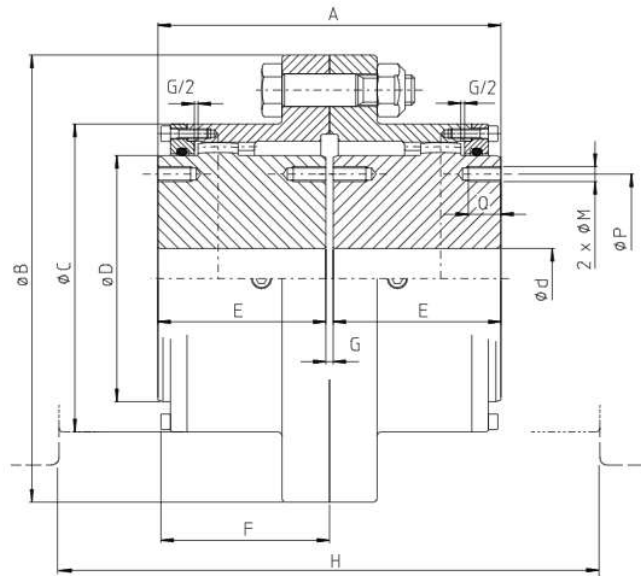

max. 1,5°

← A150		Type FST																
		280	320	360N	400N	450N	500	530	560	600	660	730	830	900	1000	1060	1130	
d Ø nominal max. d Ø min. * d Ø max.	1	mm	280	320	360	400	450	500	530	560	600	660	730	830	900	1000	1060	1130
		mm	180	200	220	260	280	300	330	350	380	420	480	540	580	640	680	740
		mm	310	340	375	420	470	500	530	560	600	660	730	830	900	1000	1060	1130
Tn 1m N·m Tp	2	Nm	244000	290000	370000	450000	560000	630000	750000	860000	1020000	1290000	2020000	2450000	3070000	3610000	4390000	5040000
		Nm	488000	580000	740000	900000	1120000	1260000	1500000	1720000	2040000	2580000	4040000	4900000	6140000	7220000	8780000	10080000
/min.max.	3	tr/min omw/min rpm min ⁻¹	1900	1800	1500	1400	1300	1150	1050	900	800	550	450	380	325	280	240	220
α	-	degré graad degree Grad	2x0,75	2x0,75	2x0,75	2x0,75	2x0,75	2x0,75	2x0,75	2x0,75	2x0,75	2x0,75	2x0,75	2x0,75	2x0,75	2x0,75	2x0,75	2x0,75
	-	mm: ±	2	2,1	2,3	2,5	2,7	2,8	3	3,2	3,4	3,6	3,7	4	4,4	4,8	5,2	5,4
J (WR ²)	4	kgm ²	20,1	31	45	68	105	164	228	313	430	685	1161	1756	2580	3690	5090	6730
	5	kg	591	760	932	1180	1532	1950	2330	2840	3370	4370	6110	7810	9730	11860	14220	16380
Grease	6	dm ³	6,44	7,6	11	12	16	18	23	25	29	39	57	77	105	130	160	180
mm: ±	A	mm	570	597	623	673	713	759	809	859	905	945	1105	1205	1285	1365	1405	1425
	B	mm	591	640	684	742	804	908	965	1029	1092	1200	1330	1440	1545	1650	1750	1860
	C	mm	472	518	562	620	682	733	787	841	892	997	1130	1240	1345	1450	1550	1660
	D	mm	394	432	480	530	594	629	673	724	772	870	965	1062	1156	1254	1346	1448
	E	mm	280	292	305	330	350	370	395	420	440	460	540	590	630	670	690	700
	F	mm	225	234	251	269	283	301	318	333	361	375	408	448	483	528	538	548
	G	mm	10	13	13	13	13	19	19	19	25	25	25	25	25	25	25	25
	H	10 mm	632	660	705	745	770	825	870	900	990	1020	1130	1210	1290	1400	1420	1440
	M	mm	M 20	M 20	M 24	M 24	M 24	M 42	M 42	M 42	M 48	M 48	M 48	M 48	M 48	M 48	M 48	M 48
	P	mm	336	377	420	480	544	568	600	642	680	765	860	950	1040	1130	1230	1300
Q	mm	30	30	40	40	40	76	76	76	82	82	82	82	82	82	82	82	

* Consult us

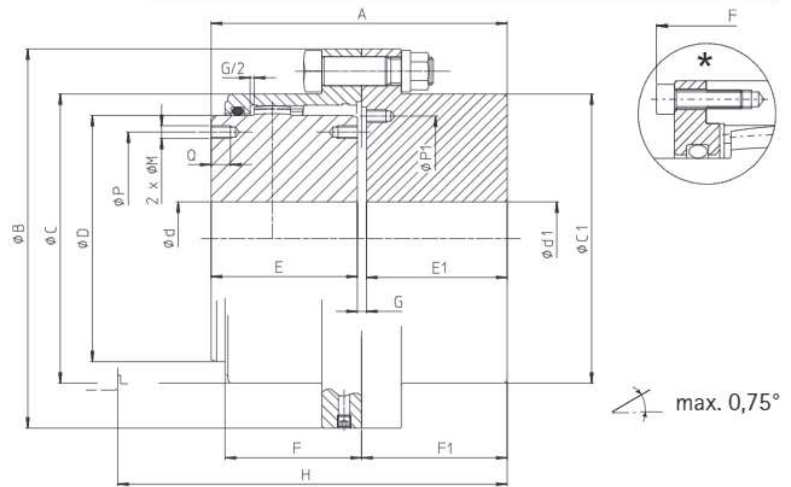
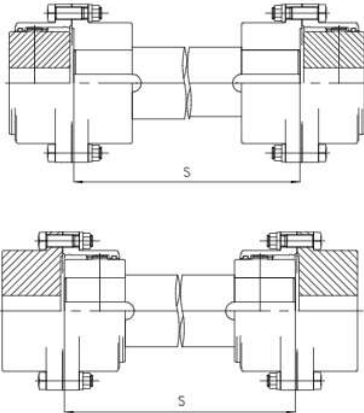

←A150		Type FFS														
		45	60	75	95	110	130	155	175	195	215	240	275	* 280	* 320	
d Ø nominal max.	mm	45	60	75	95	110	130	155	175	195	215	240	275	280	320	
	d Ø min.	1 mm	0	0	0	0	0	55	65	80	90	100	120	150	180	200
		* d Ø max.	mm	50	64	78	98	112	132	158	175	198	217	244	290	310
d1 Ø max.	1 mm	55	75	95	110	130	155	180	200	230	250	280	330	360	400	
	Ø min.	mm	0	0	0	0	0	55	65	80	90	100	120	150	180	200
Tn 1m Tp	2 Nm	1300	2800	5000	10000	16000	22000	32000	45000	62000	84000	115000	174000	244000	290000	
			2600	5600	10000	20000	32000	44000	64000	90000	124000	168000	230000	348000	488000	580000
/min.max.	3.3 tr/min omw/min rpm min ⁻¹															
α	— degré graad degree Grad	0,75	0,75	0,75	0,75	0,75	0,75	0,75	0,75	0,75	0,75	0,75	0,75	0,75	0,75	
J (WR ²)	4 kgm ²	0,005	0,016	0,040	0,107	0,197	0,446	0,868	1,362	2,584	3,900	5,650	11,446	22,6	34,5	
	5 kg	4,1	8,2	14,6	26,5	39,6	60,3	90,3	119,0	174,3	231,1	285,2	429,3	648	822	
Grease	6 dm ³	0,023	0,037	0,065	0,104	0,181	0,261	0,398	0,488	0,756	1,009	1,215	1,643	3,2	3,8	
mm: ±	A	mm	88	102	125	156	183	212,5	239,5	272	308	358	390	453	573	598,5
	B	mm	111	141	171	210	234	274	312	337	380	405	444	506	591	640
	C	mm	80	103,5	129,5	156	181	209	247	273	307	338	368	426	472	518
	C1	mm	80	103,5	126	152	178	208	245	270	305	330	362	416		
	D	mm	67	87	106	130	151	178	213	235	263	286	316	372	394	432
	E	mm	43	50	62	76	90	105	120	135	150	175	190	220	280	292
	E1	mm	40	47	58	74	87	101	113	129	150	175	190	220	280	292
	F	mm	41	47	58,5	68,5	82	98	108,5	121	132	151,5	165	183,5	225	234
	F1	mm	43,5	50,5	61,5	77,5	90,5	104,5	116,5	133	154	179	196	228	288	300
	G	mm	5	5	5	6	6	6,5	6,5	8	8	8	10	13	13	14,5
	H	10 mm	117	133,5	167,5	202	238	279,5	312,5	353	396	460	504	572	606	637
	M	mm								M 12	M 16	M 16	M 16	M 20	M 20	M 20
	P	mm								205	226	250	276	330	336	377
P1	mm								235	265	290	320	370	416	456	
Q	mm								18	24	24	24	30	30	30	

* Consult us

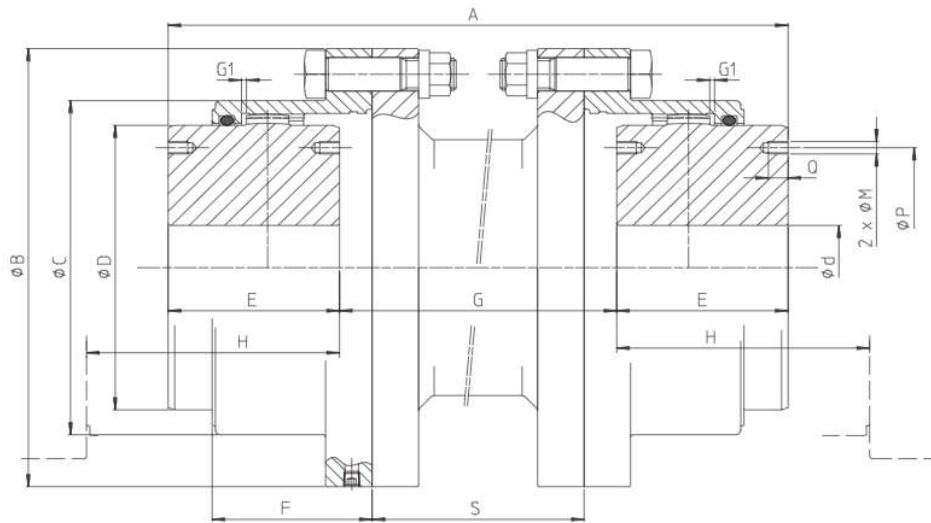

max. 1,5°

←A150		Type FSE															
		45	60	75	95	110	130	155	175	195	215	240	275	* 280	* 320		
	d Ø nominal max.	mm	45	60	75	95	110	130	155	175	195	215	240	275	280	320	
	d Ø min.	mm	0	0	0	0	0	55	65	80	90	100	120	150	180	200	
	* d Ø max.	mm	50	64	78	98	112	132	158	175	198	217	244	290	310	340	
	Tn	Nm	1300	2800	5000	10000	16000	22000	32000	45000	62000	84000	115000	174000	244000	290000	
	Tp		2600	5600	10000	20000	32000	44000	64000	90000	124000	168000	230000	348000	488000	580000	
	tr/min omw/min rpm min ⁻¹	3.3															
	degré graad degrec Grad	-	2x0,75	2x0,75	2x0,75	2x0,75	2x0,75	2x0,75	2x0,75	2x0,75	2x0,75	2x0,75	2x0,75	2x0,75	2x0,75	2x0,75	
	J (WR ²)	4.1															
		5.1															
		6	dm ³	2x0,025	2x0,037	2x0,065	2x0,105	2x0,18	2x0,26	2x0,40	2x0,49	2x0,76	2x1,01	2x1,21	2x1,64	2x3,2	2x3,8
min.	A	8	mm	167	195	245	291	323	380	412	450	516	580	624	676	780	827
	B		mm	111	141	171	210	234	274	312	337	380	405	444	506	591	640
mm: ±	C		mm	80	103,5	129,5	156	181	209	247	273	307	338	368	426	472	518
	D		mm	67	87	106	130	151	178	213	235	263	286	316	372	394	432
min.	E		mm	43	50	62	76	90	105	120	135	150	175	190	220	280	292
	F		mm	41	47	58,5	68,5	82	98	108,5	121	132	151,5	165	183,5	225	234
min.	G	8	mm	81	95	121	139	143	170	172	180	216	230	244	236	226	243
	H	10	mm	63	76	91	110	131	155	175	195	214	246	266	306	305	320
min	M		mm								M 12	M 16	M 16	M 16	M 20	M 20	M 20
	P		mm								205	226	250	276	330	336	377
	Q		mm								18	24	24	24	30	30	30
	S	8	mm	60	80	90	110	110	130	130	130	160	160	160	160	176	190
	G1		mm	1,5	1,5	1,5	2,5	2,5	3	3	4	4	4	4	5	5	6,5

* Consult us

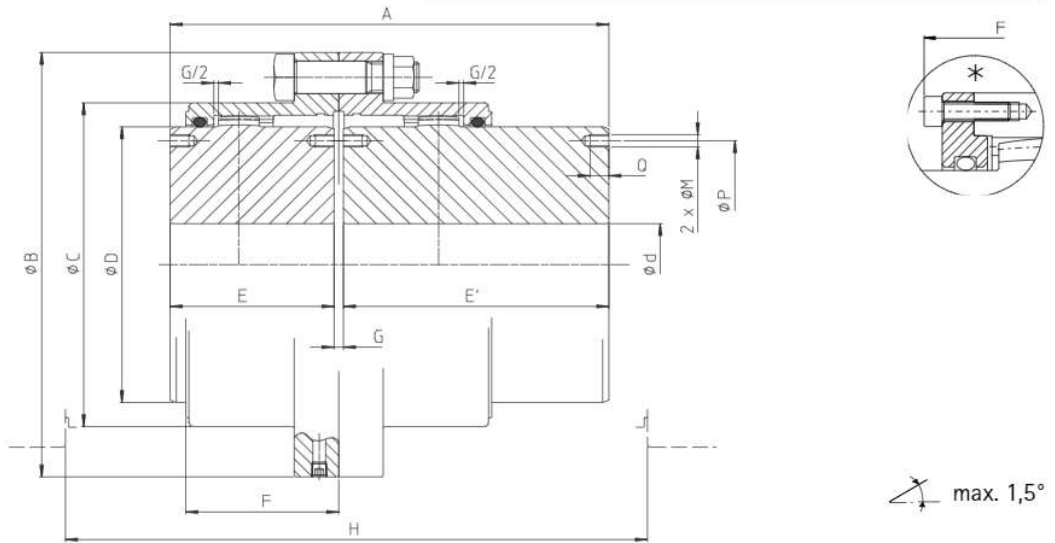

←A150		Type FMM															
		45	60	75	95	110	130	155	175	195	215	240	275	* 280	* 320		
	d Ø nominal max.	mm	45	60	75	95	110	130	155	175	195	215	240	275	280	320	
	d Ø min.	mm	0	0	0	0	0	55	65	80	90	100	120	150	180	200	
	* d Ø max.	mm	50	64	78	98	112	132	158	175	198	217	244	290	310	340	
	Tn	Nm	1300	2800	5000	10000	16000	22000	32000	45000	62000	84000	115000	174000	244000	290000	
	Tp		2600	5600	10000	20000	32000	44000	64000	90000	124000	168000	230000	348000	488000	580000	
	3.1	tr/min	5000	4400	4000	3600	3350	3100	2800	2700	2550	2450	2300	2150	1900	1800	
	3.2	rpm	7000	6200	5650	5100	4700	4350	4000	3800	3600	3450	3300	3050	2950	2800	
	—	degré grad degree Grad	2x0,75	2x0,75	2x0,75	2x0,75	2x0,75	2x0,75	2x0,75	2x0,75	2x0,75	2x0,75	2x0,75	2x0,75	2x0,75	2x0,75	
	—	mm: ±	0,35	0,4	0,5	0,6	0,7	0,9	1	1,1	1,2	1,4	1,5	1,7	2	2,1	
	4	kgm ²	0,005	0,018	0,047	0,121	0,221	0,480	0,953	1,47	2,71	4,10	6,07	12,79	22,4	35,6	
	5	kg	5,1	11,0	19,3	33,4	49,3	70,7	107	137	193	256	322	506	689	920	
	6	dm ³	0,05	0,07	0,13	0,21	0,36	0,52	0,80	0,98	1,51	2,02	2,43	3,29	6,44	7,6	
mm: ±	A	mm	126	167	195	227	260	281	316	343	378	433	478	580	700	775	
	B	mm	111	141	171	210	234	274	312	337	380	405	444	506	591	640	
	C	mm	80	103,5	129,5	156	181	209	247	273	307	338	368	426	472	518	
	D	mm	67	87	106	130	151	178	213	235	263	286	316	372	394	432	
	E	mm	43	50	62	76	90	105	120	135	150	175	190	220	280	292	
	E'	mm	80	114	130	146	165	170	190	200	220	250	280	350	410	470	
	F	mm	41	47	58,5	68,5	82	98	108,5	121	132	151,5	165	183,5	225	234	
	G	mm	3	3	3	5	5	6	6	8	8	8	8	8	10	10	13
	H	10 mm	157	200	239	276	318	351	392	440	484	562	616	704	765	805	
	M	mm								M 12	M 16	M 16	M 16	M 20	M 20	M 20	
	P	mm								205	226	250	276	330	336	377	
Q	mm								18	24	24	24	30	30	30		

* Consult us

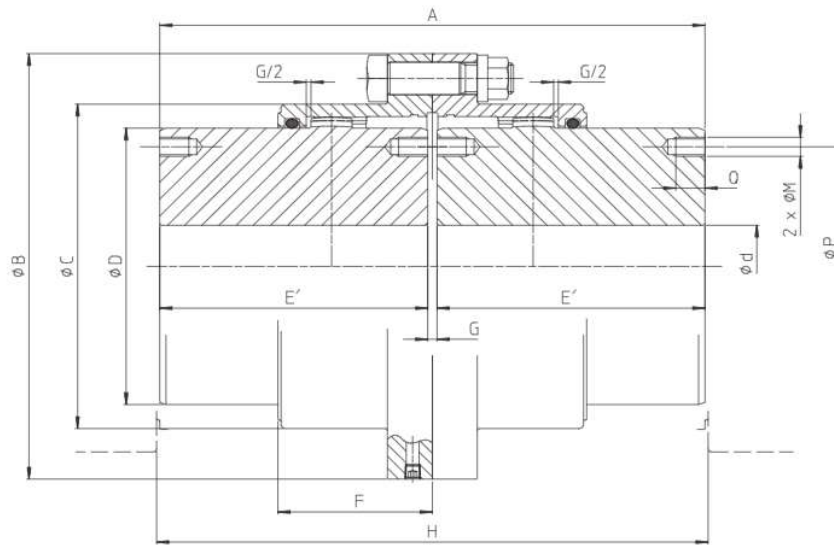

max. 1,5°

← A150		Type FDMM															
		45	60	75	95	110	130	155	175	195	215	240	275	* 280	* 320		
	d ø nominal max.	mm	45	60	75	95	110	130	155	175	195	215	240	275	280	320	
	d ø min.	mm	0	0	0	0	0	55	65	80	90	100	120	150	180	200	
	* d ø max.	mm	50	64	78	98	112	132	158	175	198	217	244	290	310	340	
	Tn	Nm	1300	2800	5000	10000	16000	22000	32000	45000	62000	84000	115000	174000	244000	290000	
	TP		2600	5600	10000	20000	32000	44000	64000	90000	124000	168000	230000	348000	488000	580000	
	3.1	tr/min	5000	4400	4000	3600	3350	3100	2800	2700	2550	2450	2300	2150	1900	1800	
	3.2	omw/min rpm min ⁻¹	7000	6200	5650	5100	4700	4350	4000	3800	3600	3450	3300	3050	2950	2800	
	—	degré graad degree Grad	2x0,75	2x0,75	2x0,75	2x0,75	2x0,75	2x0,75	2x0,75	2x0,75	2x0,75	2x0,75	2x0,75	2x0,75	2x0,75	2x0,75	
	—	mm: ±	0,35	0,4	0,5	0,6	0,7	0,9	1	1,1	1,2	1,4	1,5	1,7	2	2,1	
	4	kgm ²	0,006	0,021	0,053	0,136	0,251	0,530	1,06	1,62	2,96	4,49	6,76	14,70	24,7	40,2	
	5	kg	6,1	14,0	24,0	40,7	59,9	82,1	125	157	220	289	370	599	787	1080	
	6	dm ³	0,05	0,07	0,13	0,21	0,36	0,52	0,80	0,98	1,51	2,02	2,43	3,29	6,44	7,6	
mm: ±	A	mm	163	231	263	297	335	346	386	408	448	508	568	710	830	953	
	B	mm	111	141	171	210	234	274	312	337	380	405	444	506	591	640	
	C	mm	80	103,5	129,5	156	181	209	247	273	307	338	368	426	472	518	
	D	mm	67	87	106	130	151	178	213	235	263	286	316	372	394	432	
	E'	mm	80	114	130	146	165	170	190	200	220	250	280	350	410	470	
	F	mm	41	47	58,5	68,5	82	98	108,5	121	132	151,5	165	183,5	225	234	
	G	mm	3	3	3	5	5	6	6	8	8	8	8	10	10	13	
	H	10	mm	163	231	263	297	335	350	392	440	484	562	616	710	895	935
	M	mm								M 12	M 16	M 16	M 16	M 20	M 20	M 20	
	P	mm								205	226	250	276	330	336	377	
	Q	mm								18	24	24	24	30	30	30	

* Consult us

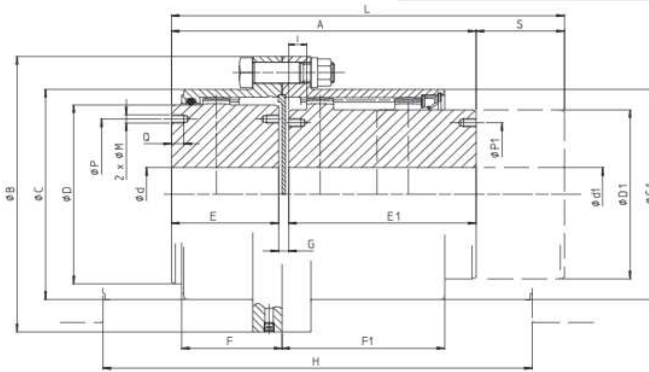

←A150			Type FSH									
			60	75	95	110	130	155	175	195	215	
d Ø nominal max. d Ø min. * d Ø max	1	mm	60	75	95	110	130	155	175	195	215	
		mm	0	0	0	0	55	65	80	90	100	
		mm	64	78	98	112	132	158	175	198	217	
Ø max. d1 Ø min.	1	mm	0	0	0	0	55	65	80	90	100	
		mm	55	70	85	100	120	140	170	190	210	
1m Nm Tn Tp	2	Nm	2800	5000	10000	16000	22000	32000	45000	62000	84000	
			5600	10000	20000	32000	44000	64000	90000	124000	168000	
/min.max.	3.3	tr/min omw/min rpm min ⁻¹										
α	4.1	degré graad degree Grad										
J (WR ²)	4.1	kgm ²										
	5.1	kg										
Grease	6.1	dm ³										
max.	A	6.1	mm	193	210	231	250	276	291	319	344	381
	B		mm	141	171	210	234	274	312	337	380	405
	C		mm	103,5	129,5	156	181	209	247	273	307	338
	C1		mm	108	129,5	156	181	209	247	270	305	330
	D		mm	87	106	130	151	178	213	235	263	286
	D1		mm	78	98	115	140	165	195	230	260	280
	E		mm	50	62	76	90	105	120	135	150	175
	E1	6.1	mm	135	140	145	150	160	160	170	180	190
	F		mm	47	58,5	68,5	82	98	108,5	121	132	151,5
max.	F1	6.1	mm	138	139	144	157	159	162	168	168	179
min.	G	min	mm	8	8	10	10	11	11	14	14	16
max.	H	10	mm	247	276	300	330	370	385	425	460	510
max.	I		mm	10	10	10	10	10	10	15	15	15
	L	6.1	mm	278	290	311	340	361	371	394	414	451
max.	M		mm							M12	M 12	M 16
	P		mm							205	226	250
	P1		mm							200	225	245
	Q		mm							18	18	24
	S	7	mm	85	80	80	90	85	80	75	70	70

* Consult us

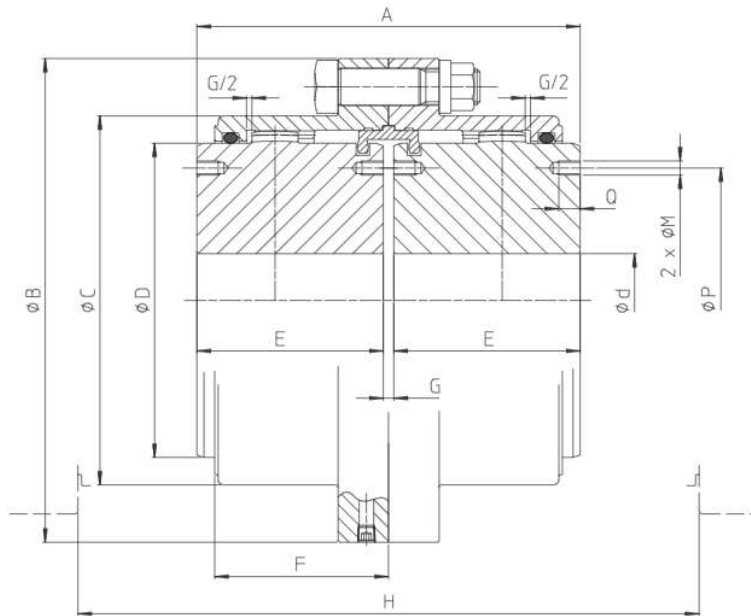

max.
NOUS CONSULTER
ONS RAADPLEGEN
REFER TO FACTORY
AUF ANFRAGE

		Type FLE												
		45	60	75	95	110	130	155	175	195	215	240	275	
d nominal max. d min. * d max	1	mm	45	60	75	95	110	130	155	175	195	215	240	275
		mm	0	0	0	0	55	65	80	90	100	120	150	
		mm	50	64	78	98	112	132	158	175	198	217	244	290
Tn Tp	2	Nm	1300	2800	5000	10000	16000	22000	32000	45000	62000	84000	115000	174000
		Nm	2600	5600	10000	20000	32000	44000	64000	90000	124000	168000	230000	348000
/min.max.	3.1	tr/min omw/min	5000	4400	4000	3600	3350	3100	2800	2700	25550	2450	2300	2150
	3.2	rpm min ⁻¹	7000	6200	5650	5100	4700	4350	4000	3800	3600	3450	3300	3050
J (WR ²)	4	kgm ²	0,005	0,015	0,040	0,105	0,191	0,430	0,842	1,32	2,45	3,72	5,38	10,87
	5	kg	4,1	8,0	14,6	26,1	38,8	59,2	89,4	118	167	222	275	414
Grease	6	dm ³	2x0,025	2x0,037	2x0,065	2x0,105	2x0,18	2x0,26	2x0,40	2x0,49	2x0,76	2x1,01	2x1,21	2x1,64
mm: ±	A	mm	89	103	127	157	185	216	246	278	308	358	388	450
	B	mm	117	141	171	210	234	274	312	337	380	405	444	506
	C	mm	80	103,5	129,5	156	181	209	247	273	307	338	368	426
	D	mm	67	87	106	130	151	178	213	235	263	286	316	372
	E	mm	43	50	62	76	90	105	120	135	150	175	190	220
	F	mm	41	47	58,5	68,5	82	98	108,5	121	132	151,5	165	183,5
	G	mm	3	3	3	5	5	6	6	8	8	8	8	10
	H	mm	147	166	212	249	295	350	392	440	484	562	616	688
	M	mm								M 12	M 16	M 16	M 16	M 20
	P	mm								205	226	250	276	330
Q	mm								18	24	24	24	30	

* Consult us

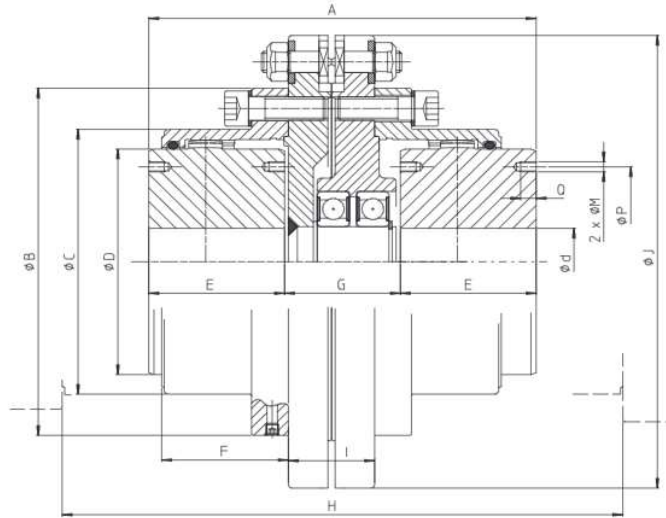

max. 1,5°

		Type FSP													
			45	60	75	95	110	130	155	175	195	215	240	275	
←A150 	d Ø nominal max.	mm	45	60	75	95	110	130	155	175	195	215	240	275	
	d Ø min.	mm	0	0	0	0	0	55	65	80	90	100	120	150	
	*d Ø max.	mm	50	64	78	98	112	132	158	175	198	217	244	290	
	Tn	Nm	750	1800	3500	7000	11000	15500	22000	31500	43500	55000	81000	122500	
	Tp		1500	3600	7000	14000	22000	31000	44000	63000	87000	110000	162000	245000	
	tr/min min.max.	tr/min omw/min rpm min ⁻¹	4000	3600	3300	2950	2550	2150	2000	1800	1650	1450	1400	1350	
	α	degré graad degree Grad	2x0,75	2x0,75	2x0,75	2x0,75	2x0,75	2x0,75	2x0,75	2x0,75	2x0,75	2x0,75	2x0,75	2x0,75	
	mm: ±	mm: ±	0,6	0,7	0,8	0,9	1	1,2	1,3	1,4	1,5	1,9	2,0	2,3	
	J (WR ²)	kgm ²	0,019	0,055	0,098	0,272	0,448	1,01	1,75	2,77	4,61	6,82	9,68	18,4	
		kg	8,5	16,9	26,5	45,1	62,5	99,5	139	183	247	316	395	579	
	Grease	dm ³	2x0,025	2x0,037	2x0,065	2x0,105	2x0,18	2x0,26	2x0,40	2x0,49	2x0,76	2x1,01	2x1,21	2x1,64	
mm: ±	A	mm	131	153	185	217	247	293	324	363	396	467	504	579	
	B	mm	111	141	171	210	234	274	312	337	380	405	444	506	
	C	mm	80	103,5	129,5	156	181	209	247	273	307	338	368	426	
	D	mm	67	87	106	130	151	178	213	235	263	286	316	372	
	E	mm	43	50	62	76	90	105	120	135	150	175	190	220	
	F	mm	41	47	58,5	68,5	82	98	108,5	121	132	151,5	165	183,5	
	G	9	mm	45	53	61	65	67	83	84	93	96	117	124	139
	H	10	mm	189	216	270	309	357	427	470	525	572	671	732	817
	I	mm	33	44	44	48	48	60	60	64	64	78	78	96	
	J	mm	155	194	228	267	300	358	384	428	470	524	560	656	
	M	mm								M 12	M 16	M 16	M 16	M 20	
P	mm								205	226	250	276	330		
Q	mm								18	24	24	24	30		

* Consult us

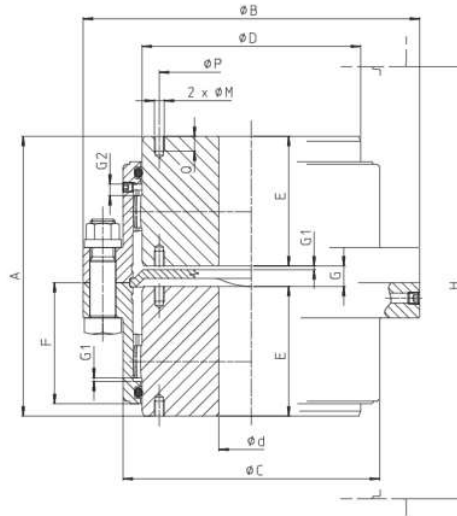

max. 1,5°

La cote G ne peut varier en cours de fonctionnement
 Maat G mag niet gewijzigd worden bij werking
 Distance G may not vary during operation
 Das Maß "G" muß während des Betriebs konstant bleiben

← A150		Type FSV												
		45	60	75	95	110	130	155	175	195	215	240	275	
	d Ø nominal max.	mm	45	60	75	95	110	130	155	175	195	215	240	275
	d Ø min.	mm	0	0	0	0	0	55	65	80	90	100	120	150
	* d Ø max.	mm	50	64	78	98	112	132	158	175	198	217	244	290
	Tn	Nm	1300	2800	5000	10000	16000	22000	32000	45000	62000	84000	115000	174000
	1m Tp		2600	5600	10000	20000	32000	44000	64000	90000	124000	168000	230000	348000
	tr/min rpm min ⁻¹	min.max.	5000	4400	4000	3600	3350	3100	2800	2700	2550	2450	2300	2150
	degré graad degree Grad		2x0,75	2x0,75	2x0,75	2x0,75	2x0,75	2x0,75	2x0,75	2x0,75	2x0,75	2x0,5	2x0,5	2x0,5
	mm: ±		0,35	0,4	0,5	0,6	0,7	0,9	1	1,1	1,2	0,9	1	1,1
	J (WR ²)	kgm ²	0,005	0,015	0,040	0,105	0,191	0,430	0,842	1,32	2,45	3,72	5,38	10,9
	kg		4,1	8,0	14,6	26,1	38,8	59,2	89,4	118	167	222	275	414
	dm ³		2x0,021	2x0,037	2x0,057	2x0,104	2x0,164	2x0,254	2x0,387	2x0,514	2x0,741	2x0,940	2x1,12	2x1,69
mm: ±	A	mm	94	105	136,5	163	193	224	255	287	320	377	414	468
	B	mm	111	141	171	210	234	274	312	337	380	405	444	506
	C	mm	80	103,5	129,5	156	181	209	247	273	307	338	368	426
	D	mm	67	87	106	130	151	178	213	235	263	286	316	372
	E	mm	43	50	62	76	90	105	120	135	150	175	190	220
	F	mm	41	47	58,5	68,5	82	98	108,5	121	132	151,5	165	183,5
	G	9 mm	8	5	12,5	11	13	14	15	17	20	27	34	28
	G1	9 mm	1,5	1,5	1,5	2,5	2,5	3	3	4	4	4	4	5
	G2	9 mm	5,5	5,5	6	8,5	8,5	12	12	16	16	16	16	20
	H	10 mm	147	166	212	249	295	350	392	440	484	562	616	688
	M	mm								M 12	M 16	M 16	M 16	M 20
	P	mm								205	226	250	276	330
Q	mm								18	24	24	24	30	

* Consult us

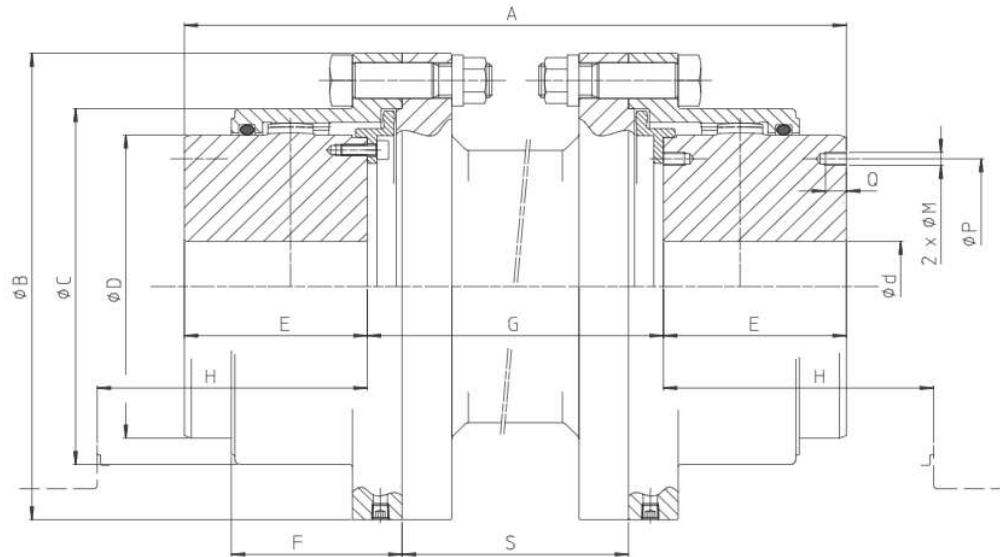



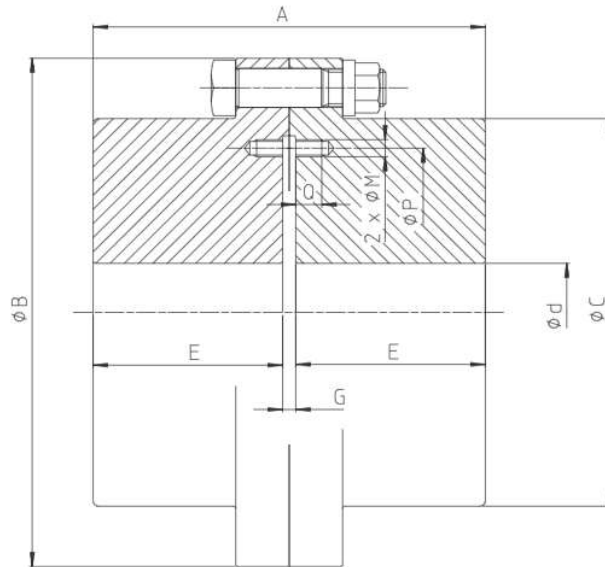

max.
 NOUS CONSULTER
 ONS RAADPLEGEN
 REFER TO FACTORY
 AUF ANFRAGE

←A150		Type FSLE													
		45	60	75	95	110	130	155	175	195	215	240	275		
d Ø nominal max. d Ø min. * d Ø max	1	mm	45	60	75	95	110	130	155	175	195	215	240	275	
		mm	0	0	0	0	0	55	65	80	90	100	120	150	
		mm	50	64	78	98	112	132	158	175	198	217	244	290	
Tn 1m Tp	2	Nm	1300	2800	5000	10000	16000	22000	32000	45000	62000	84000	115000	174000	
			2600	5600	10000	20000	32000	44000	64000	90000	124000	168000	230000	348000	
/min.max.	3.3	tr/min omw/min rpm min ⁻¹													
J (WR ²)	4.1	kgm ²													
	5.1	kg													
Grease	6	dm ³	2x0,025	2x0,037	2x0,065	2x0,105	2x0,18	2x0,26	2x0,40	2x0,49	2x0,76	2x1,01	2x1,21	2x1,64	
mini mm: ± mini mini	A	mm	167	195	245	291	323	380	412	450	516	580	624	676	
	B	mm	111	141	171	210	234	274	312	337	380	405	444	506	
	C	mm	80	103,5	129,5	156	181	209	247	273	307	338	368	426	
	D	mm	67	87	106	130	151	178	213	235	263	286	316	372	
	E	mm	43	50	62	76	90	105	120	135	150	175	190	220	
	F	mm	41	47	58,5	68,5	82	98	108,5	121	132	151,5	165	183,5	
	G	8	mm	81	95	121	139	143	170	172	180	216	230	244	236
	G1	mm	1,5	1,5	1,5	2,5	2,5	3	3	4	4	4	4	5	
	H	10	mm	63	76	91	110	131	155	175	195	214	246	266	306
	M	mm									M 12	M 16	M 16	M 16	M 20
	P	mm									205	226	250	276	330
	Q	mm									18	24	24	24	30
	S	8	mm	60	80	90	110	110	130	130	130	10	160	160	160

* Consult us



			Type FRR													
			45	60	75	95	110	130	155	175	195	215	240	275		
	d Ø max. d Ø min.	1	mm	55	75	95	110	130	155	180	200	230	250	280	330	
			mm	0	0	0	0	0	55	65	80	90	100	120	150	
	Tn Tp	2	Nm	1300	2800	5000	10000	16000	22000	32000	45000	62000	84000	115000	174000	
				2600	5600	10000	20000	32000	44000	64000	90000	124000	168000	230000	348000	
	/min.max.	3.3	tr/min omw/min rpm min ⁻¹	6000	5500	5000	4400	4000	3500	3000	2700	2500	2200	2100	2000	
	J (WR ²)	4	kgm ²	0,005	0,017	0,041	0,109	0,203	0,459	0,9	1,4	2,7	4,1	6,0	12,0	
		5.1	kg	4,4	8,4	14,6	26,9	40,4	62,2	92,1	123	185	244	308	461	
mini	A		mm	87	101	123	155	181	209	233	266	308	358	392	456	
	B		mm	111	141	171	210	234	274	312	337	380	405	444	506	
	C		mm	80	103,5	126	152	178	208	245	270	305	330	362	416	
	E		mm	40	47	58	74	87	101	113	129	150	175	190	220	
	G		mm	7	7	7	7	7	7	7	7	8	8	8	12	16
	M		mm									M 12	M 16	M 16	M 16	M 20
	P		mm									235	265	290	320	370
mm: ±	Q		mm								18	24	24	24	30	

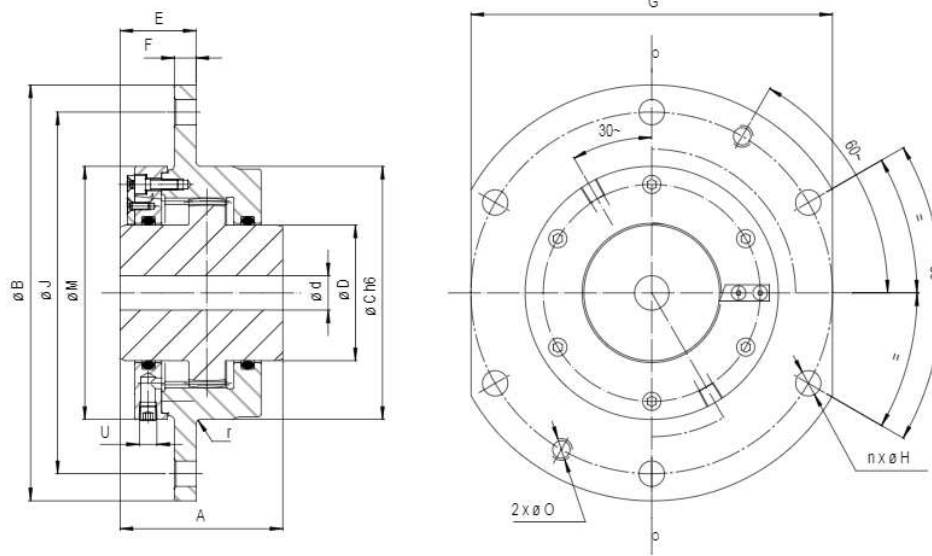

←A150	ESCO	150	170	220	250	280	300	320	380	420	
	SEB	SG130	SG140	SG185	SG200	SG240	SG270	SG315	SG355	SG400	
d	\varnothing max.	150	170	220	250	280	300	320	380	420	
	\varnothing min.	65	80	120	150	180	190	200	220	260	
$1m$	T_n	37	62	130	160	310	385	500	660	800	
	T_p	74	124	260	320	620	770	1000	1320	1600	
RADIAL LOAD	kN	88	112	188	221	314	343	399	499	587	
ΔK_W	degré graad degree Grad	0,75	0,75	0,75	0,75	0,75	0,75	0,75	0,75	0,75	
ΔK_a	mm: \pm	7	8	8	8	8	8	10	10	10	
J (WR ²)	kgm ²	0,78	1,69	4,7	6,4	13,6	18,1	25,2	42,2	62	
	kg	69	105	198	235	370	460	560	760	940	
Grease	dm ³	0,20	0,39	0,54	0,59	0,91	1,17	1,83	1,98	2,41	
mm: \pm	A	170	185	240	260	315	350	380	410	450	
	B	400	450	550	580	650	680	710	780	850	
	C	280	340	420	450	530	560	600	670	730	
	D	220	240	320	350	410	440	470	536	580	
	E	45	60	60	60	65	65	81	81	81	
	F	15	20	20	20	25	25	35	35	35	
	G	360	400	500	530	580	600	640	700	760	
	H	19	24	24	24	24	24	28	28	28	
	J	360	400	500	530	600	630	660	730	800	
	M	279	339	419	449	529	559	599	669	729	
	O	mm	M 16	M 20	M 20	M 20	M 20	M 20	M 20	M 20	M 20
	n	-	10	10	10	14	14	26	26	26	26
	r	mm	2,5	2,5	2,5	2,5	2,5	4	4	4	4
	u	R"	1/8	1/4	1/4	1/4	1/4	1/4	1/4	1/4	1/4

TORQUE CONTROL DEVICES

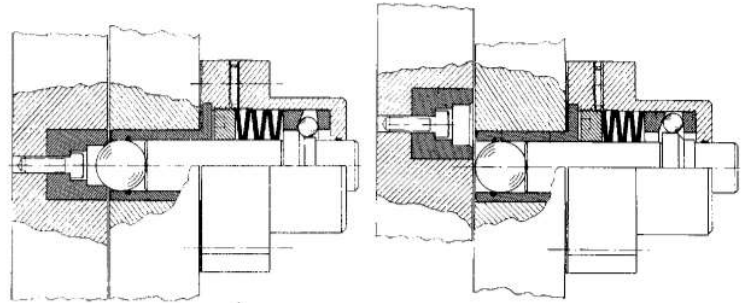
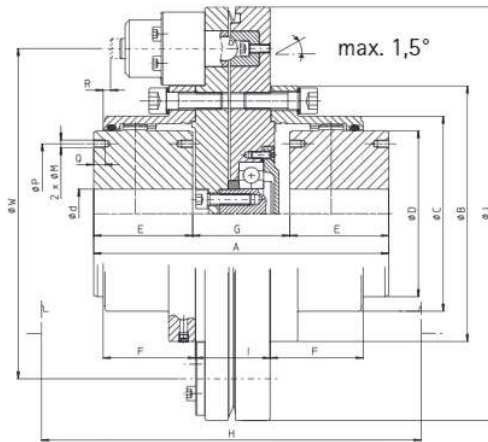

engagé - eingeschaltet - engaged

désengagé - ausgeschaltet - disengaged

		Type FET												
			60/1	75/1	95/2	110/2	130/3	155/3	175/4	195/4	215/5	240/5	275/6	
	d Ø nominal max.	mm	60	75	95	110	130	155	175	195	215	240	275	
	d Ø min.	mm	0	0	0	0	55	65	80	90	100	120	150	
	* d Ø max.	mm	64	78	98	112	132	158	175	198	217	244	290	
	Tn		2800	5000	10000	16000	22000	32000	45000	62000	84000	115000	174000	
	TR	Nm	1010	1010	1930	1930	7140	7140	11320	11320	34900	34900	57600	
	min.	tr/min omw/min rpm min ⁻¹	3600	3300	2950	2550	2150	2000	1800	1650	1450	1400	1350	
	max.		5600	8180	15600	15600	44000	57200	90000	90750	168000	230000	348000	
	α	degré graad degree Grad	2x0,75	2x0,75	2x0,75	2x0,75	2x0,75	2x0,75	2x0,75	2x0,75	2x0,75	2x0,75	2x0,75	
	mm: ±	mm: ±	0,7	0,8	1	1,1	1,4	1,5	1,7	1,8	2,2	2,3	2,7	
	J (WR ²)	kgm ²	0,271	0,323	0,733	0,862	3,84	4,59	7,83	9,28	26,4	31,6	58,9	
	kg	kg	33,1	41,6	67,9	82,5	184	222	290	345	587	681	1017	
	dm ³	dm ³	2x0,037	2x0,065	2x0,105	2x0,18	2x0,26	2x0,40	2x0,49	2x0,76	2x1,01	2x1,21	2x1,64	
mm: ±	A	mm	161	193	228	258	325	356	391	424	512	549	630	
	B	mm	141	171	210	234	274	312	337	380	405	444	506	
	C	mm	103,5	129,5	156	181	209	247	273	307	338	368	426	
	D	mm	87	106	130	151	178	213	235	263	286	316	372	
	E	mm	50	62	76	90	105	120	135	150	175	190	220	
	F	mm	47	58,5	68,5	82	98	108,5	121	132	151,5	165	183,5	
	G	mm	61	69	76	78	115	116	121	124	162	169	190	
	H	10 mm	mm	224	278	320	368	459	502	553	600	716	777	868
	I	mm	mm	52	52	59	89	92	92	92	123	123	147	
	J	mm	mm	288	288	350	350	464	464	538	538	706	706	844
	M	mm								M 12	M 16	M 16	M 16	M 20
	P	mm								205	226	250	276	330
	Q	mm								18	24	24	24	30
	R	mm		- 9,5	1	16	28,5	13	20,5	35	45	12,5	37	80,5
W	mm		230	230	292	292	390	390	464	464	582	582	720	

* Consult us

Caractéristiques principales – Voornaamste karakteristieken – Main features – Viktiga fördelar
 Charakteristische Hauptmerkmale – Caracteristicas principales – Caratteristiche principali

- 3 POSITIONS MOYEUR
- 3 NAVENPOSITIES
- 3 HUBS POSITIONS
- 3 EINBAUMÖGLICHKEITEN
- 3 NAVKOMBINATIONER
- 3 POSICIONES CUBO
- 3 POSIZIONI DEI MOZZI

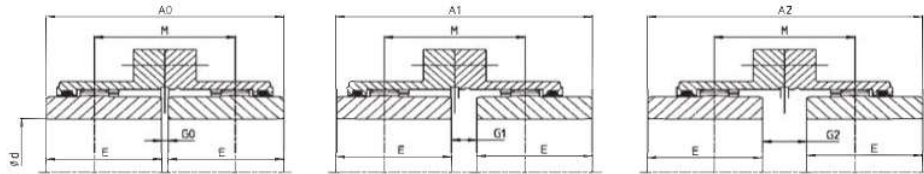

←A105 d Ø nominal max.		Type FST																	
		45	60	75	95	110	130	155	175	195	215	240	275	280*	320*	360N*	400N*	450N*	
d Ø min.		mm	0	0	0	0	0	55	65	80	90	100	120	150	180	200	220	260	280
*d Ø max.		mm	50	65	78	98	112	132	158	175	198	212	244	290	310	340	390	435	485
A0		mm	89	103	127	157	185	216	246	278	308	358	388	450	570	597	623	673	713
A1		mm	98	109	141	169	199	233	264	299	332	389	426	483	590	617	658	713	761
A2		mm	107	115	155	181	213	250	282	320	356	420	464	516	610	637	693	753	809
E		mm	43	50	62	76	90	105	120	135	150	175	190	220	280	292	305	330	350
G0		mm	3	3	3	5	5	6	6	8	8	8	8	10	10	13	13	13	13
G1		mm	12	9	17	17	19	23	24	29	32	39	46	43	30	33	48	53	61
G2		mm	21	15	31	29	33	40	42	50	56	70	84	76	50	53	83	93	109
M		mm	55	59	79	93	109	128	144	164	182	214	236	263	310	325	353	383	411

*Consult us

4 ALTERNATIVES – 4 ALTERNATIEVEN – 4 ALTERNATIV – 4 AUSFUEHRUNGEN – 4 ALTERNATIVAS – 4 ALTERNATIVE

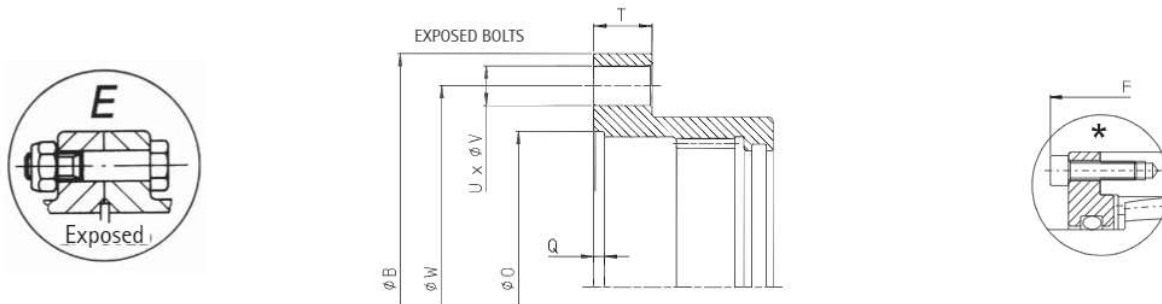

Type ⇨		(1)	(1 1/2)	(2)	(2 1/2)	(3)	(3 1/2)	(4)	(4 1/2)	(5)	(5 1/2)	(6)	(7)	(8)*	*	*	*	*
Flange Connection	B mm	111	141	171	210	234	274	312	337	380	405	444	506	591	640	684	742	804
	O mm	78	100	120	144	170	198	234	256	290	315	345	400	451	483	540	590	660
	Q mm	3,5	3,5	3,5	3,5	3,5	3,5	3,5	4	4	4	6	8	8	8	8	10	10
	T mm	14	19	19	22	22	28,5	28,5	28,5	38	38	26	28,5	33	38	38	38	38
Exposed Metric (E.M.)	U Qty.	6	8	6	6	8	8	8	10	10	14	14	16	14	18	24	28	30
	V mm	9	11	13	17	17	21	21	21	21	21	25	25	32	32	32	32	32
	W mm	96	122	150	184	208	242	280	305	345	368	406	460	530	580	624	682	744
Exposed Inch (E.I.)	U Qty.	6	8	6	6	8	8	8	10	8	14	14	16	16				
	V inch.	0,250	0,375	0,500	0,625	0,625	0,750	0,750	0,750	0,875	0,875	0,875	1,000	1,125				
	W inch.	3,750	4,812	5,875	7,125	8,125	9,5	11	12	13,5	14,5	15,75	18,25	20,75				